

9630

Cassetta smontaggio/rimontaggio per pompe BOSCH tipo PES... M e PES... RSF (9 articoli - 18 pezzi)... **MERCEDES...**

Tool box for disassembly and reassembly of PES... M BOSCH pumps and PES... RSF (9 articles - 18 pcs)... **MERCEDES...**

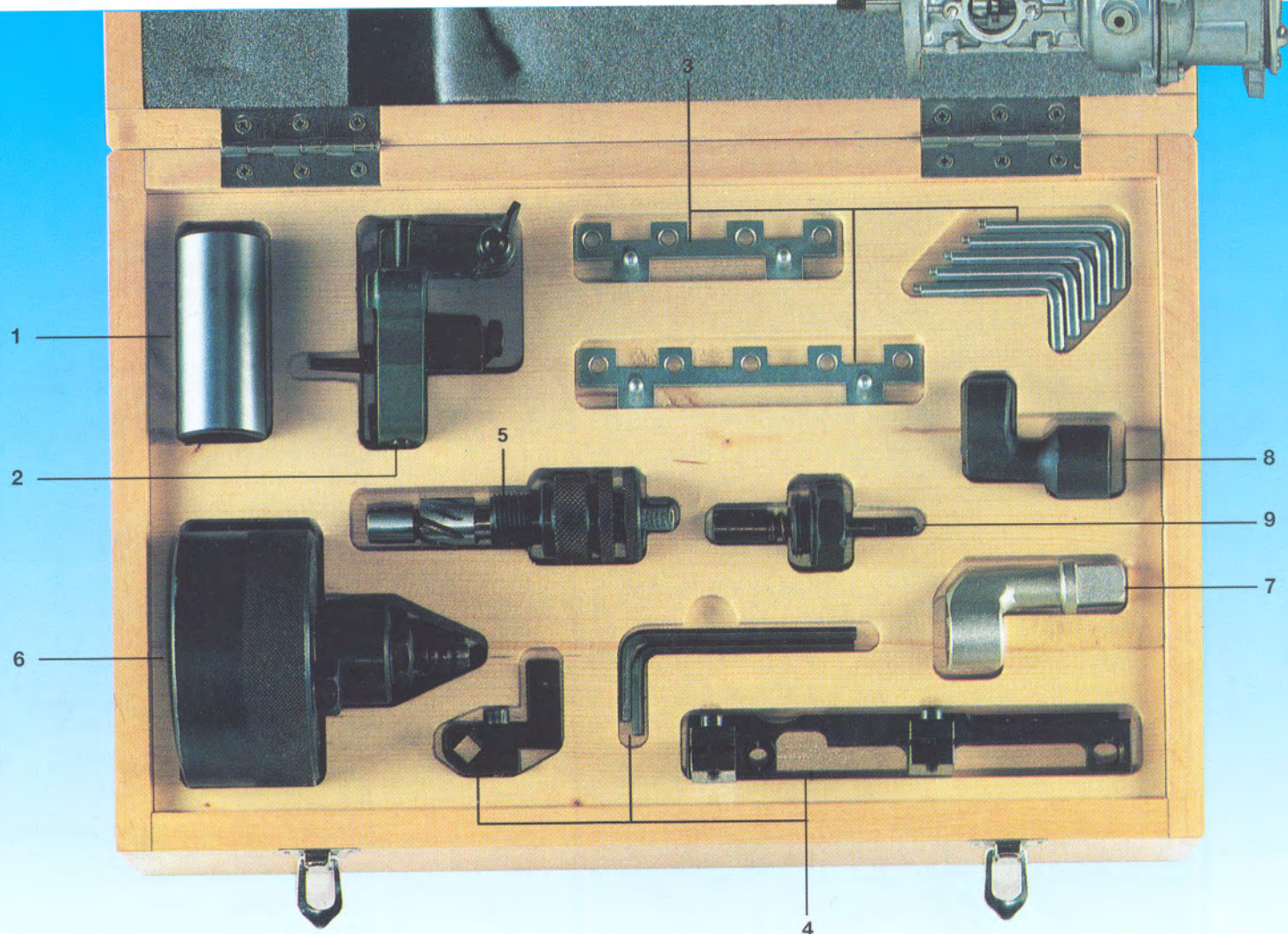

1	9529 (Rif. KDEP 1044)	Chiave dentata PES... RSF... M Toothed wrench PES... RSF... M
2	9454 (Rif. BH 0681440017)	Supporto comparatore inizio mandata Dial gauge bearing for delivery start
3	9238/D (Rif. KDEP 1563)	Alza punteria PES 4 cilindri e 5 cilindri Tappet lifter for PES 4 and 5 cyl.
4	9881/A (Sost./Replaces Rif. 1688130130)	Supporto comparatore corsa asta per PES... M e PES... RSF 4 e 5 cilindri Rod stroke dial gauge bearing for PES... M and PES... RSF 4 and 5 cyl.
5	9333 (Rif. KDEP 2956)	Fresa base pompante PES... M Bed pumping reamer
6	9587 (Rif. KDEP 1045)	Campana per controllo tenuta olio Checking bell for oil seal
7	9554	Chiave poligonale aperta da 17 mm Open box wrench - Ø 17 mm
8	9554/A	Chiave poligonale aperta da 17 mm con quadro 1/2" Open box wrench - Ø 17 mm 1/2" square
9	9760 (Rif. KDEP 1077)	Ferma fase PES... RSF (Mercedes 190D) PES... RSF stroke stop (Mercedes 190D)

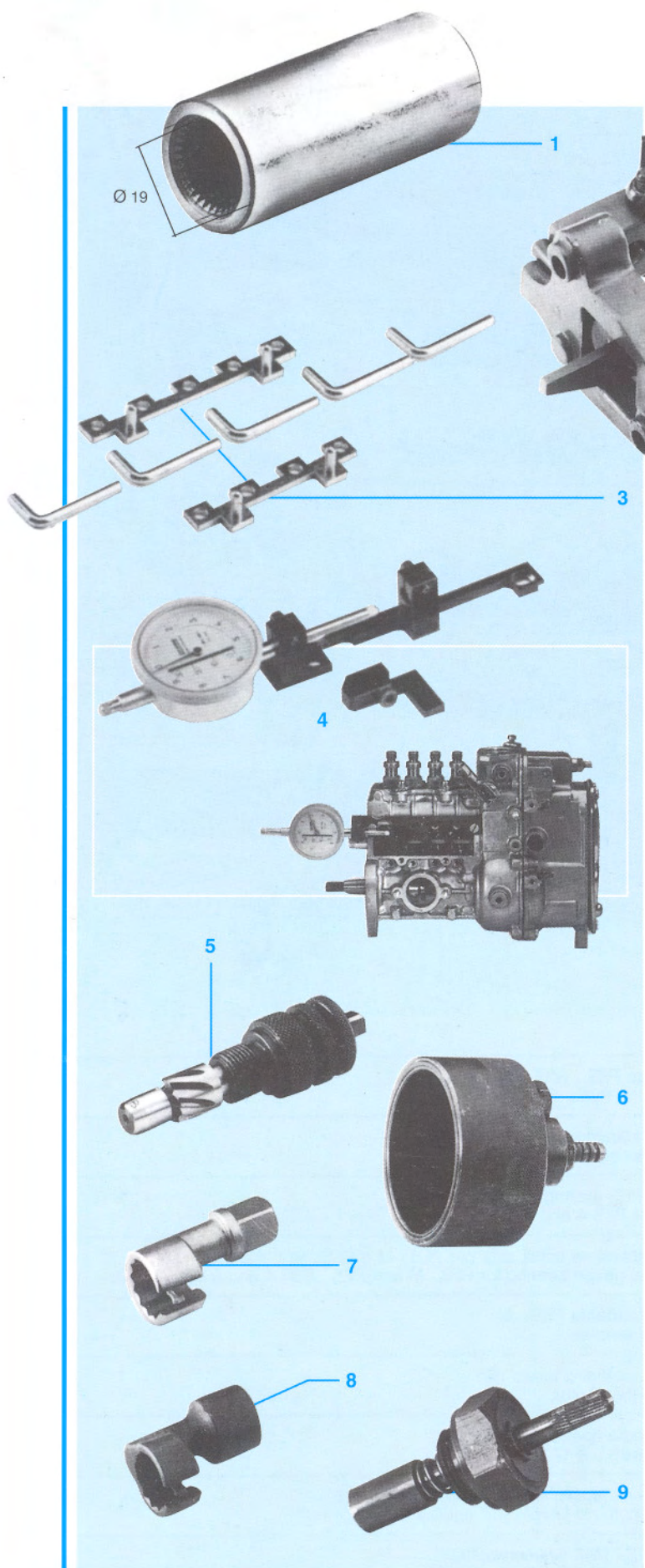

- 1 9529** (Rif. KDEP 1044)
 Chiave dentata PES...RSF...M
 (Mercedes 190D-250D)
(KDEP Ref. 1044)
 Toothed wrench PES... RSF...M
 (Mercedes 190D - 250D)
- 2 9454** (Rif. BH 0681440017)
 Supporto comparatore inizio
 mandata PES...M (Mercedes 220D -
 Ford Transit)
(BH Ref. 0681440017)
 PES...M dial gauge bearing for delivery
 start (Mercedes 220D - Ford Transit)
- 3 9238/D** (Rif. KDEP 1563)
 Alza punteria PES...M...RSF 4 cil. - 5 cil.
 (Mercedes 220 - 190 - 250D - Ford Transit)
(KDEP Ref. 1563)
 Tappet lifter for PES...M...RSF - 4 and 5 cyl.
 (Mercedes 220D - 190D - 250D -
 Ford Transit)
- 9238/E** (Rif. BH KDEP 1563/3)
 Alza punteria PES...M 6 cil.
 con 6 eccentrici
(BH Ref. KDEP 1563/3)
 Plate for PES...M 6 cil.
 complete of six tappets lighter
- 4 9881/A** (Sost. Rif. 1688130130)
 Supporto comparatore corsa asta
 cremagliera per PES...M...RSF, 4 cil. e 5 cil.
 (Mercedes 220-190-250D - Ford Transit).
 (Comparatore n/s art. 9500 - mm 30
 decimale escluso)
(Replaces Ref. 1688130130)
 Rod stroke dial gauge bearing for
 PES...M...RSF - 4 and 5 cil.
 (Mercedes 220D-190D-250D - Ford Transit).
 The dial gauge is our art. 9500 -
 30 mm decimal. (Not included)
- 5 9333** (Rif. KDEP 2956)
 Fresa base pompante PES...M (Ø mm 12x16)
 (Mercedes - Ford Transit)
(KDEP Ref. 2956)
 Bed pumping reamer PES...M - Ø 12x16 mm
 (Mercedes and Ford Transit)
- 6 9587** (Rif. KDEP 1056)
 Campana per controllo tenuta olio pompe
 PES...M ecc. con immissione di aria
 compressa
(KDEP Ref. 1056)
 Checking bell for oil
 seal for PES...M pumps
 with compressed air inlet
- 7 9554** Chiave poligonale da
 mm 17 per dadi
 tubazione
 17 mm open box
 wrench for pipe nuts
- 8 9554/A** Chiave poligonale
 aperta da mm 17 per
 dadi tubazione
 17 mm open box
 wrench for pipe nuts
- 9 9760** (Rif. KDEP 1077)
 Ferma fase PES...RSF
 (Mercedes 190D-250D)
(KDEP Ref. 1077)
 PES...RSF stroke stop (Mercedes 190D)



Staffe pompe SIMMS-BOSCH PES... Caterpillar

Brackets for SIMMS-BOSCH PES... Caterpillar pumps

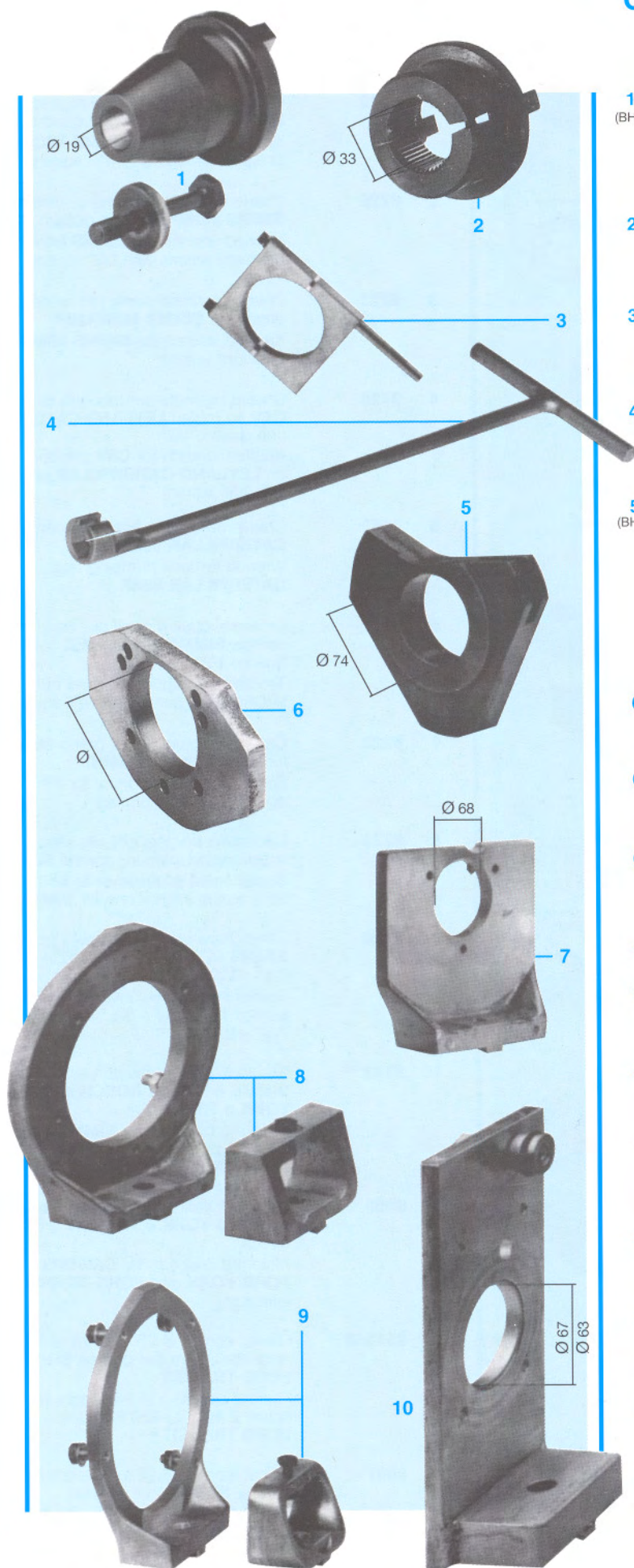

- 1 9747**
(BH Rif. 1686 432 022)
Giunto dentato pompe **BOSCH PES...RSF** (Mercedes 190D-250D)
Toothed coupling for **BOSCH PES...RSF** pumps (Mercedes 190D-250D)
- 2 9153**
Giunto dentato pompe **BOSCH PES...M** (Mercedes 220D)
Toothed coupling for **BOSCH PES...M** pumps (Mercedes 220D)
- 3 9405**
(Rif. BH KDEP 1545)
Morsetto ferma giunto 9747 sul banco prova (KDEP Ref. 1545)
Clamp to fix our coupling 9747 on the test bench
- 4 9403**
Chiave a T da 14 per dadi tubazione su **MERCEDES 190D**
14 mm T wrench for pipe nuts on **MERCEDES 190D**
- 5 9746**
(BH Rif. 1685 720 208)
Staffa per pompe **BOSCH PES...RSF...M** (Mercedes 190D) sul banco **BOSCH**.
Adattabile alla n/s culla:
9680 Culla banco **BOSCH**
9679 Culla banco **RABOTTI** ecc.
Bracket for **BOSCH PES...RSF...M** pumps on **BOSCH** test bench.
Adaptable to:
9680 - cradle for **BOSCH** test bench
9679 - cradle for **RABOTTI** test bench etc.
- 6 9478/A**
Flangia per pompe **BOSCH PES...M** (Mercedes - Volvo) - Ø 68 mm
Bracket for **BOSCH PES...M** pumps (Mercedes - Volvo) - Ø 68 mm
- 6 9478/E**
Flangia per pompe **CAV-DPS** Ø 68 mm (Ford Transit)
Bracket for **CAV-DPS** pumps - Ø 68 mm (Ford Transit)
- 6 9478/F**
Flangia per pompe **CATERPILLAR** serie SLIV - Ø 95 mm
Bracket for **CATERPILLAR** pumps SLIV series - Ø 95 mm
- 7 9745**
Staffa per pompe **PES...M** su banco **BOSCH**
Bracket for **PES...M** pumps on **BOSCH** test bench
- 7 9745/A**
Staffa per pompe **PES...M** su banco **RABOTTI**
Bracket for **PES...M** pumps on **RABOTTI** test bench
- 8 9215**
Staffa per pompe **SIMMS/BOSCH PES** (Ford Transit) su banco **RABOTTI**
Bracket for **SIMMS/BOSCH PES** pumps (Ford Transit) on **RABOTTI** test bench
- 8 9364**
Staffa per pompe **SIMMS/BOSCH PES** (Ford Transit) su banco **BOSCH**
Bracket for **SIMMS/BOSCH PES** pumps (Ford Transit) on **BOSCH** test bench
- 9 9342**
Staffa per pompe **SIMMS** industriale su banco **RABOTTI**
Bracket for industrial **SIMMS** pumps on **RABOTTI** test bench
- 9 9367**
Staffa per pompe **SIMMS** industriale su banco **BOSCH**
Bracket for industrial **SIMMS** pumps on **BOSCH** test bench
- 10 9480**
Staffa per pompe **CATERPILLAR** serie 955K ecc. su banco **RABOTTI**
Bracket for **CATERPILLAR** pumps 955K series etc. on **RABOTTI** test bench
- 10 9481**
Idem su banco **BOSCH**
Same on **BOSCH** test bench

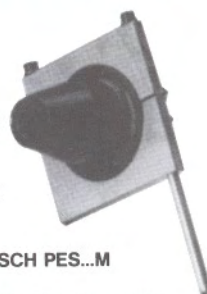

Attrezzatura pompe SIMMS-CAV

Equipment for SIMMS-CAV pumps

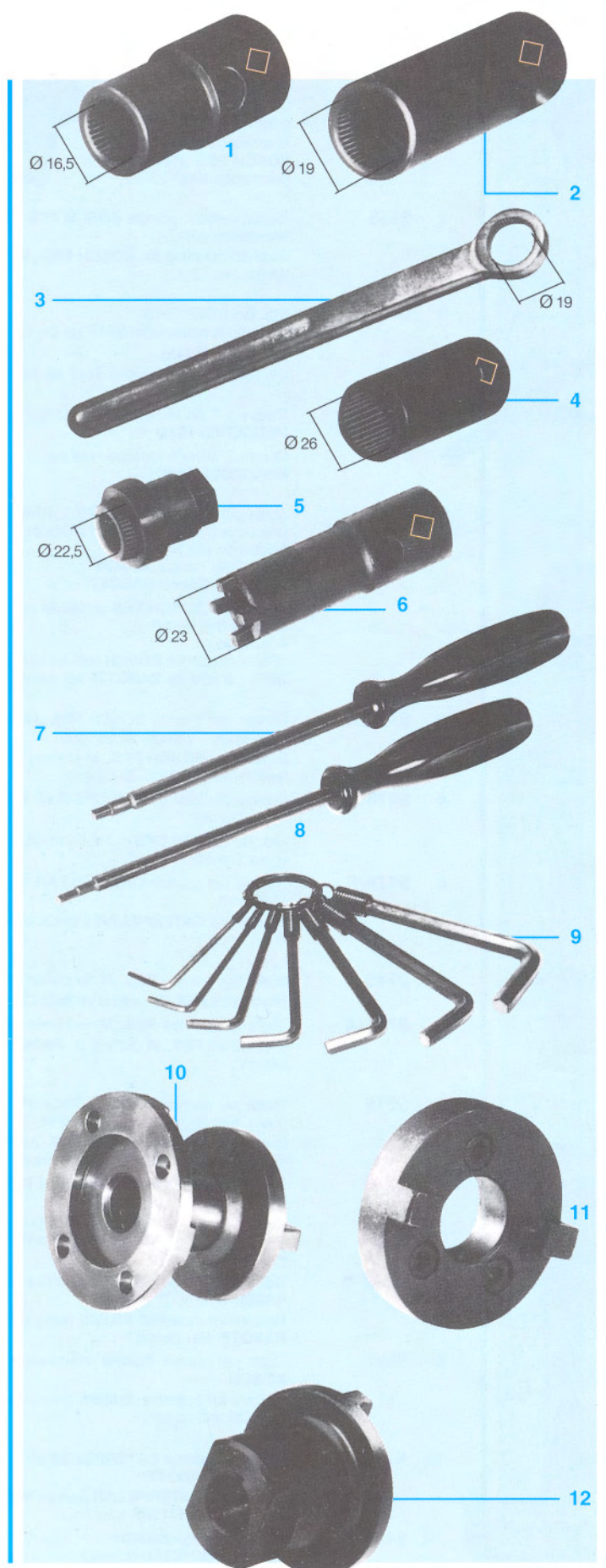

- 1 9218** Chiave zigrinata raccordi di pressione **SIMMS MICROMECC** con quadro 1/2"
Knurled wrench for **SIMMS MICROMECC** pressure unions with 1/2" square
- 2 9728** Chiave zigrinata raccordi di pressione **SIMMS MINIPUMP** con quadro 1/2"
Knurled wrench for **SIMMS MINIPUMP** pressure unions with 1/2" square
- 3 9222** Chiave zigrinata piana per raccordi di pressione **SIMMS MINIPUMP**
Knurled wrench for **SIMMS MINIPUMP** pressure unions
- 4 9726** Chiave zigrinata per raccordi di pressione **CAV** su motori **LEYLAND-CATERPILLAR** con quadro 1/2"
Knurled wrench for **CAV** pressure unions on **LEYLAND-CATERPILLAR** engines with 1/2" square
- 5 9057** Chiave per ghiera fissa pompante **CATERPILLAR 955K** ecc.
Wrench for lock pumping ring **CATERPILLAR 955K** etc.
- 6 9217** Chiave a quattro denti per dado anteriore pompa **SIMMS MICROMECC** con quadro 1/2"
Toothed wrench for the front nut of **SIMMS MICROMECC** pump with 1/2" square
- 7 9223** Cacciavite brugola per grano fissa forcellino pompe **SIMMS**
Socket head screwdriver for the fixing fork dowel of **SIMMS** pumps
- 8 9224** Cacciavite brugola per vite fissa corpo superiore od inferiore pompe **SIMMS**
Socket head screwdriver to fix the upper body to the inferior one for **SIMMS** pumps
- 9 9220** Serie chiavi brugola in pollici per pompe **SIMMS** 1/6" - 5/64" - 3/32" - 1/8" - 3/16" - 7/32" - 1/4"
Socket head screwdriver kit for **SIMMS** pumps 1/6" - 5/64" - 3/32" - 1/8" - 3/16" - 7/32" - 1/4"
- 10 9343** Giunto di trascinamento per pompe **SIMMS** e **PES...M BOSCH** su **FORD YORK** e **TRANSIT**
Motoring coupling for **SIMMS** and **PES...M BOSCH** pumps on **FORD YORK** and **FORD TRANSIT**
- 11 9865** Giunto di trascinamento pompa **CAV-DPS** su **FORD YORK** e **TRANSIT** a iniezione diretta
Motoring coupling for **CAV-DPS** pump on **FORD YORK** and **FORD TRANSIT** direct injection
- 12 9578/A** Giunto conico Ø 20 lunghezza 60 chiavella 2 mm per pompe **BH/VE** su **FORD TRANSIT**
Conical coupling Ø 20, length 60, spline 2 mm, for **BH/VE** pumps on **FORD TRANSIT**
- 12 9867** Giunto conico Ø 22 lunghezza 70 per pompe **SIMMS** 6 cil. in linea
Conical coupling Ø 22, length 70 mm for **SIMMS** pumps 6 cyl. in line